

STENNER PUMPS®

PERISTALTIC METERING PUMPS SINCE 1957

BASIC SERVICE MANUAL

Classic Series Pumps

BASIC SERVICE MANUAL

Classic Series Pumps

The Classic Series peristaltic metering pumps are electromechanical and during their service life will require maintenance.

Use this manual to identify wear parts, learn solutions, and implement preventative maintenance for optimal product performance.

Always follow safety & operational instructions in the Classic Series manual. The pump is designed for installation and service by properly trained personnel.



Meet Max the Tube... the one who does all the work. Look for Max in the manual and in Stenner media and let him be your pumping pal so you get the most from your Stenner pump.



Videos & Literature



techsupport@stenner.com

Table of Contents

GENERAL INFORMATION

Safety Information	5
Supplies	6
Classic Series Single Head Adjustable Pump	7

INSTALLATION POINTS

Installation Diagram	8
Installation	9
Suction and Discharge Lines	10
Connections	11

SUBASSEMBLY CONNECTIONS

Rivet and Slot Identification	12
Separate Subassemblies	13
Reconnect Subassemblies	14

PUMP TUBE

Pump Tube Basics	15
Maximize Tube Life	16
Visual Reference	17
Poor Conditions Reduce Tube Life	18-20
Tube Replacement	21-28
Pump Head Replacement	29-30

FEED RATE CONTROL

Feed Rate Control Basics	31
Feed Rate Control Wear	32-33
Feed Rate Control Parts Replacement	34-35

MOTOR

Motor Basics	36
Motor Malfunction Causes	37
Rotor Assembly Replacement	38
Coil Replacement	39-42
Gears	43-44
Gear Wear	45
Gear Replacement	46

Look for *all*
Stenner Pumps
& Products on
back pages

BSME 042524

Safety Information

⚠ WARNING To be installed and maintained by properly trained professional installer only. Read manual & labels for all safety information & instructions.

ⓘ NOTICE: Indicates special instructions or general mandatory action.

ⓘ Before installing or servicing the pump, read the pump manual for all safety information and complete instructions. The pump is designed for installation and service by properly trained personnel.

⚠ WARNING HAZARDOUS VOLTAGE:
DISCONNECT power cord before removing motor cover for service. **Electrical service by trained personnel only.**

⚠ WARNING HAZARDOUS PRESSURE/CHEMICAL EXPOSURE

⚠ Use caution and bleed off any system pressure prior to attempting service or installation.

⚠ Use caution when disconnecting discharge line from pump. Discharge may be under pressure. Discharge line may contain chemical.

⚠ WARNING RISK OF CHEMICAL EXPOSURE:
Potential for chemical burns, fire, explosion, personal injury, or property damage. To reduce risk of exposure, the use of proper personal protective equipment is mandatory.

Supplies

- ✓ #2 Phillips head screwdriver
- ✓ Flat head screwdriver
- ✓ 3/8" open end wrench (to change index pin lifter)
- ✓ Aquashield
- ✓ Non-citrus cleaner
- ✓ Needle-nose pliers
- ✓ Utility knife



Classic Series Single Head Adjustable Pump

THREE SUBASSEMBLIES

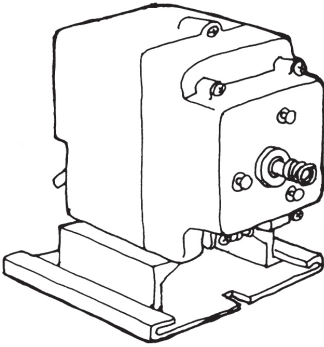

Motor

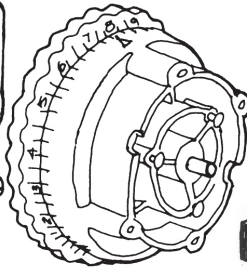

Feed Rate Control
(FRC)

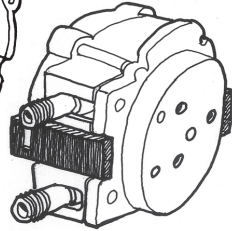

Pump Head

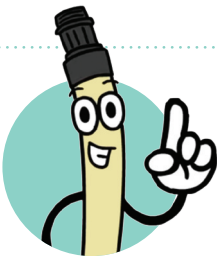

Subassemblies make replacement in the field quick & convenient.

Installation Diagram for Single Head Pump

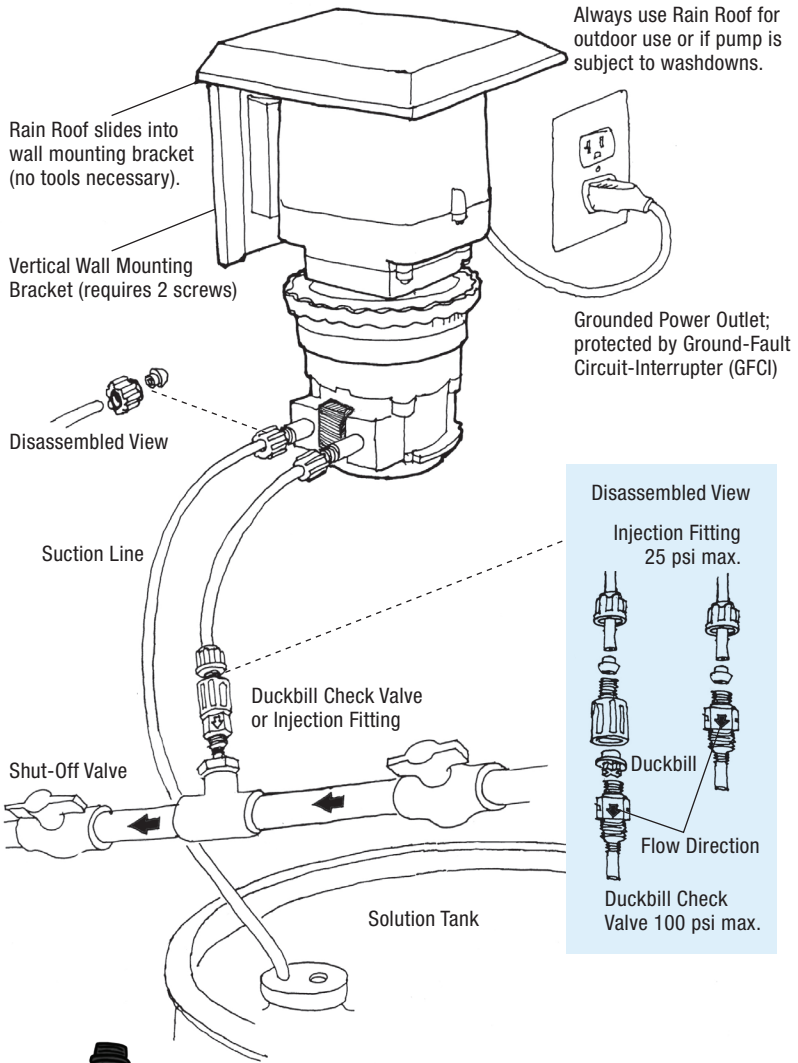

Protect your investment!
Install your pump right the *first time*.

Installation

Mount the single head pump vertically and use the spill recovery to drain chemical back to the tank in the event of tube failure. Vertical installation will help prevent chemical from collecting in the tube housing and on the floor. The spill recovery setup is not recommended for acid applications.

Horizontal mounting is recommended for double head pumps to keep chemical from collecting in the pump head if the tube ruptures.

Always follow proper safety and installation instructions according to the manual and check your local codes for additional guidelines.

Vertical Mount with Rain Roof

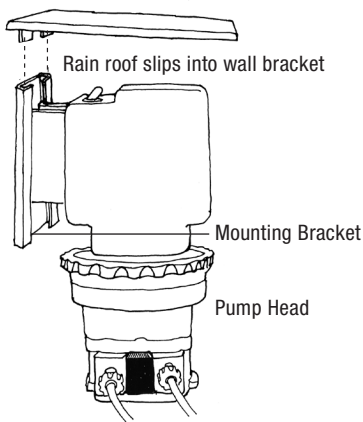

The pump motor is ventilated and water intrusion causes motor damage.

The rain roof, sold separately, is recommended for outdoor and wet environments.

Spill Recovery Setup

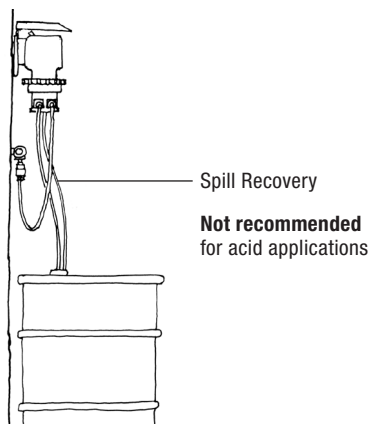
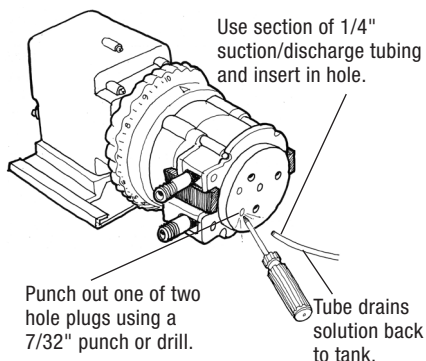

Suction and Discharge Lines



Allow slack in both the suction & discharge lines to prevent stress on the tube and fittings. The slack allows the tube fittings to flex to help reduce the chance of breakage and leaks.

The suction line should not be flush with the nose of the strainer. Install the strainer 3" from the tank bottom to prevent picking up sediment.

Sediment drawn from the tank bottom damages the tube and causes blockage in the check valve, duckbill & discharge line and the pump may not prime.

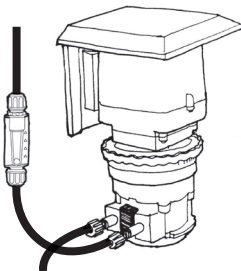
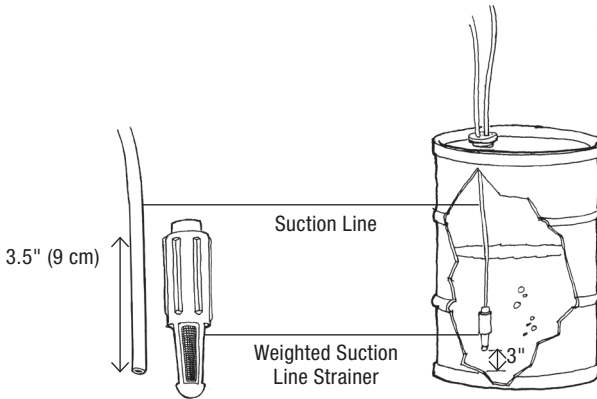
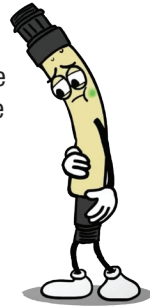

Install the Flow Indicator on the discharge line as a visual guide to confirm the pump is injecting.

Use Stenner UV black Suction/ Discharge Tubing & Rain Roof for outdoor installations.

Connections

The connections to the pump tube fittings and to the injector are a compression type seal. Overtightening the connections breaks the seal and can cause a twisted tube, damaged fittings, or crushed ferrules.

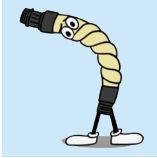

A twisted tube will not stay centered & decreases tube life.

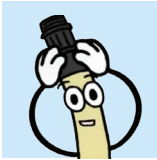

Always hold tube fitting firmly when reconnecting the nut to prevent twisting.

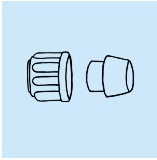

1/4" LINES: Use 1/4" NUT & FERRULE

Beveled end of ferrule must face away from nut. Suction & discharge lines must bottom into tube fitting. Nut & ferrule are finger tightened.

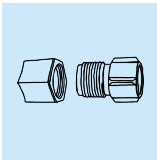

3/8" LINE TO INJECTOR: Use 3/8" NUT

Line slides through nut & is finger tightened onto injector; wrench tightened another 1/2 turn. If leak occurs, nut is gradually tightened.

3/8" LINE to TUBE FITTING: Use 3/8" NUT & ADAPTER

Adapter is finger tightened onto tube fitting. Line slides through nut & is finger tightened onto adapter and wrench tightened another 1/2 turn. If leak occurs, nut is gradually tightened.

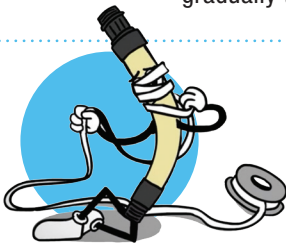

DO NOT use thread seal tape, it interferes with the compression seal and causes leaks.

Rivet and Slot Identification

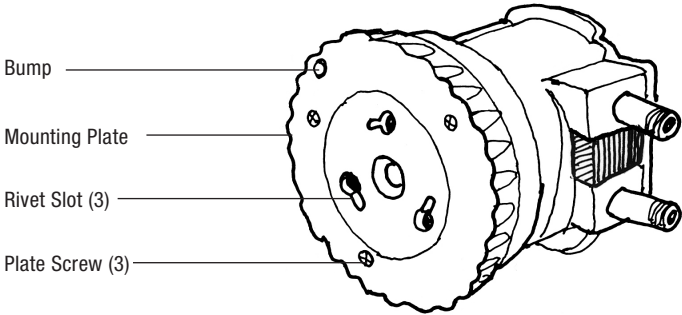
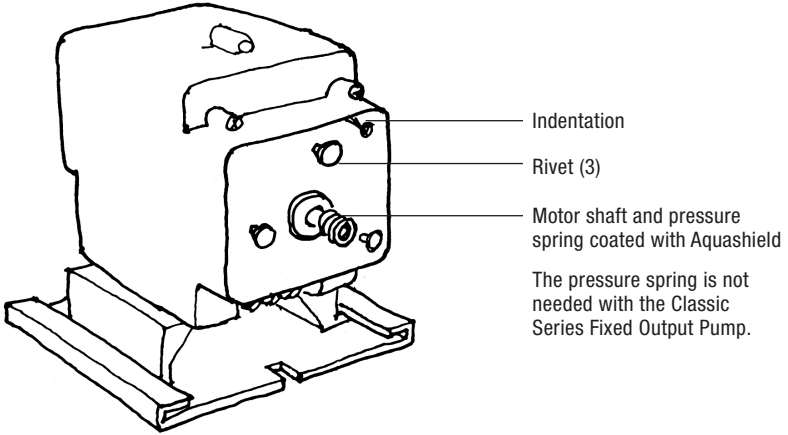

Separate Subassemblies

1. Turn pump off and unplug power cord.
2. Hold feed rate control & turn pump head clockwise until it stops.
3. Pull pump head straight out.
4. Hold motor, grasp feed rate control & turn clockwise until it stops.
5. Pull feed rate control straight out.

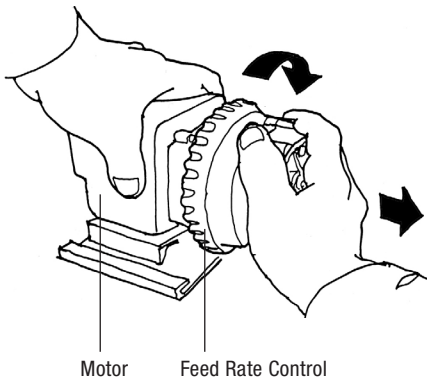
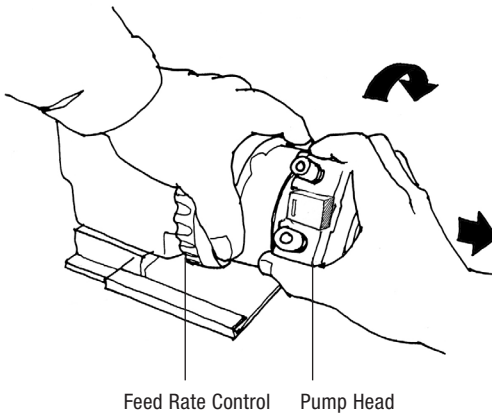

Reconnect Subassemblies

RECONNECT FEED RATE CONTROL TO MOTOR

1. On adjustable models, confirm pressure spring is in place, then slide feed rate control onto the shaft.
2. Turn the feed rate control counterclockwise to line up the flat side of the motor shaft (d shaft) with the flat side of the spider in the feed rate control and push towards the motor.
3. Push and turn the feed rate control until the rivets on the gear case are inside the rivet holes on the feed rate.
4. Turn counterclockwise until it locks into place and the bump on the feed rate mounting plate fits into the indentation in the gear case cover. The arrow on the feed rate control should be on top.

RECONNECT PUMP HEAD TO FEED RATE CONTROL

Refer to page 29 and follow Pump Head Replacement instructions, steps 1d through 4.

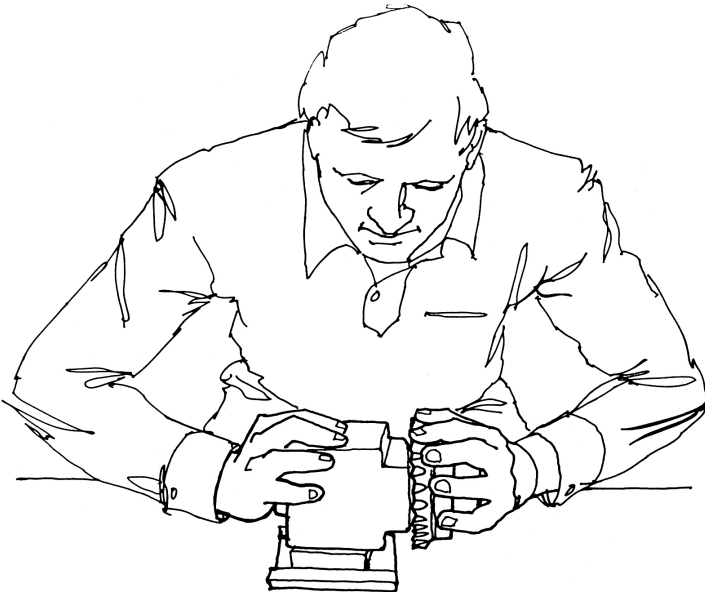

Pump Tube Basics

1. The tube is the workhorse of the pump and is perishable. It will eventually reach the end of its service life, indicated by:
 - Tube leak
 - Reduction or lack of output
2. The very first tube replacement indicates the expected service life for the tube & the specific application *if* other conditions are not the cause.
3. Before tube replacement, confirm if the tube reached its expected life or correct what has caused reduced service life.

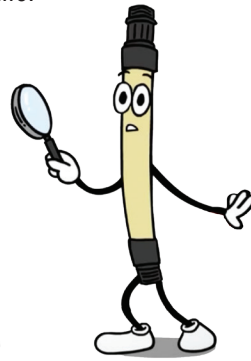
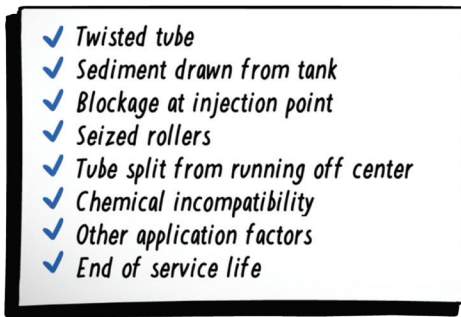

NOTE: Refer to the Chemical Resistance Guide in the Catalog for material compatibility.

4. Create a schedule for routine tube replacement and pump maintenance.



5. Always follow complete safety & operational instructions in the pump manual.

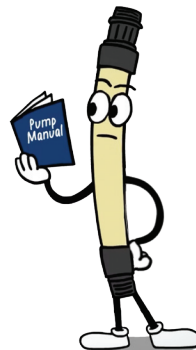

Maximize Tube Life



DO NOT use pliers to secure connections or ferrules can be damaged. The 1/4" connecting nut must be finger tightened only.

DO NOT pull on the tube fittings to stretch the tube. Follow instructions in the manual to run the roller assembly in the collapsed position 4 minutes to relax tube.

DO NOT lubricate the tube & roller assembly; it compromises the material.

DO NOT use thread seal tape on connectors; the tape prevents connectors from seating properly and can cause leaks.

DO NOT stress the tube & fittings; allow enough slack in the suction and discharge lines for the fittings to flex.

DO NOT allow tube fittings to turn inside the tube housing when connecting suction & discharge line. The tube will be forced off center and will rub against the housing edge causing it to split and leak.

DO NOT store tubes in high ambient temperatures or in direct sunlight; it weakens tube material.

Pump Tube Pressure Rating

Pump Tube	25 psi (1.7 bar) max.	100 psi (6.9 bar) max. Check valve required
1	✓	✓
2	✓	✓
3	✓	
4	✓	
5	✓	
7*		✓

* Classic Single Head only

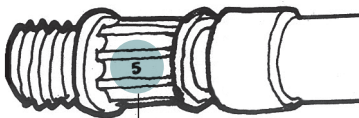

Tube number located on fitting

Visual Reference



When the tube is pressed against the tube housing wall, the shape formed can be used as a visual reference.

A tear drop pattern is normal and confirms the roller assembly has been expanded after tube replacement.

A diamond pattern indicates excessive back pressure. Excessive back pressure is caused by any blockage, or a clogged duckbill or when the system pressure exceeds the tube pressure rating.

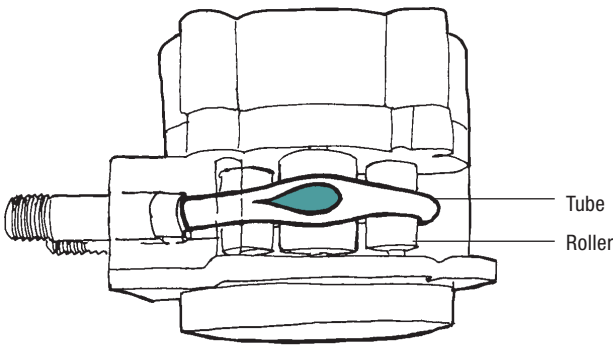
An oval pattern indicates worn rollers and/or the tube has reached the end of its service life. Tubes can rupture without a diamond or oval pattern apparent.



-  Diamond
Excessive pressure or blockage
-  Tear Drop
Normal
-  Oval
Fatigued tube or worn rollers or housing

Poor Conditions Reduce Tube Life

SEIZED ROLLERS

Chemical exposure allows corrosive chemicals to collect on the roller bushings causing rollers to seize. Seized rollers stretch and pull instead of smoothly rolling over the tube.

SOLUTION

1. Confirm chemical compatibility with housing and tube material.
2. Review factory installation instructions.
3. Rinse chemical residue from housing & roller assembly with factory recommended cleaners and dry or replace roller assembly.
4. Replace the pump tube.
5. If tube housing is cracked, replace.

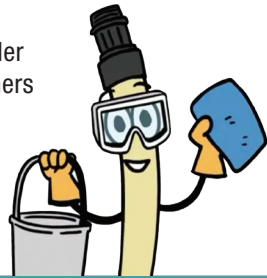

WORN ROLLERS

Worn rollers can cause reduced output or a lack of output. An indentation in the roller(s) prevents the rollers from fully pressing the tube against the housing wall to pump.

Confirm rollers turn freely and are not worn

SOLUTION

1. Replace the roller assembly.
2. Replace the tube.

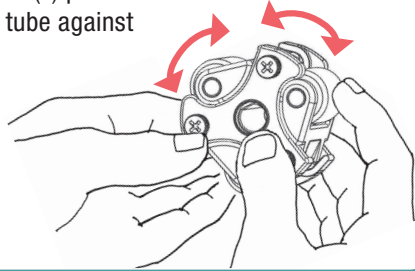

Poor Conditions Reduce Tube Life

EXCESSIVE BACK PRESSURE AT THE POINT OF INJECTION

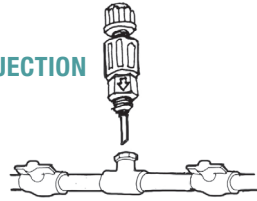

DISCHARGE LINE

Calcium or mineral deposits in the injection fitting can cause blockage or restriction creating back pressure exceeding the tube pressure rating.

SOLUTION

1. Insert #2 Phillips head screwdriver through injection fitting into the pipe to break up accumulated deposits. If screwdriver can't be inserted, drill out the deposit. Do not drill through the opposite pipe wall.
2. If using a duckbill check valve, replace duckbill.

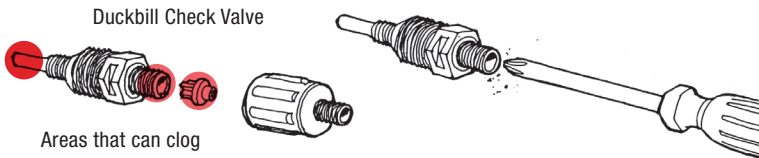

SUCTION LINE

Insoluble sediments drawn through the suction line from the tank bottom can cause blockage in the check valve creating excessive pressure and damaging the tube.

SOLUTION

1. Replace suction line; clean sediment from bottom.
2. Position strainer 3" from tank bottom.
3. If using a duckbill check valve, replace duckbill.

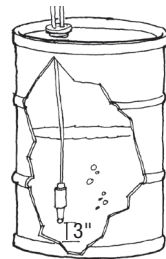

Poor Conditions Reduce Tube Life

SPLIT ALONG SIDE OF THE TUBE

If the tube is not centered and it continuously rides against the edge of the tube housing, it will split.

SOLUTION

Always follow the tube replacement instructions in the manual which includes centering the tube.

NOTE: The tube will not center if it is twisted during installation or if the rollers are worn. The tube can also twist if the tube fitting isn't stabilized when tightening connections.

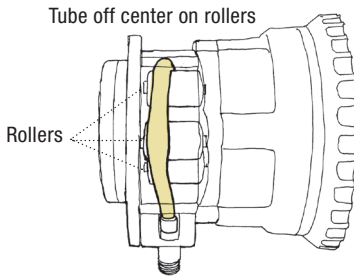

Tube Replacement

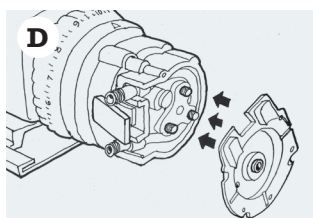
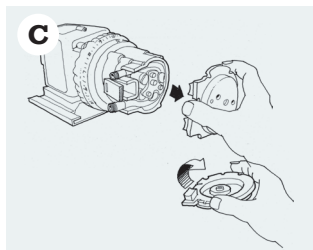
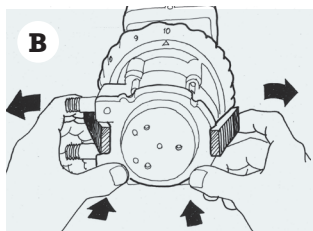
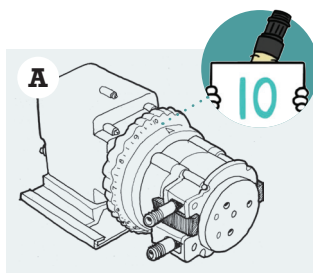

PREPARATION

1. Follow all safety precautions prior to tube replacement.
2. Prior to service, pump water or a compatible buffer solution through the pump and suction & discharge lines to remove chemical and avoid contact.

REMOVE TUBE

1. Turn pump off and unplug power cord. On the adjustable model, ensure feed rate control is set to 10. **A**
2. Depressurize and disconnect the suction & discharge lines.
3. Open latches on both sides of head. Carefully fold latches back to prevent contact with the cover. **B**

CE PUMP ONLY: Remove safety screw on cover.

4. Remove tube housing cover and flip to use as a tool in next step. **C**
5. Position cover feet at 10 o'clock. Place cover holes onto knurled lugs on roller assembly. If using a Double Head Pump, slide innermost cover on shaft and position rivets next to knurled lugs on roller assembly. **D**

Tube Replacement

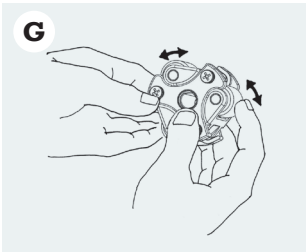
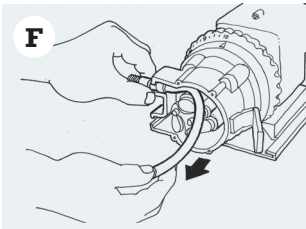
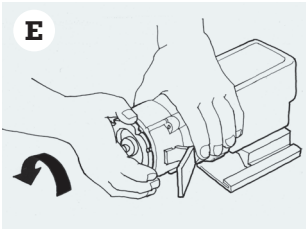

REMOVE TUBE continued

- Securely hold feed rate or motor (on fixed rate pump). Quickly (snap) rotate cover counterclockwise to collapse roller assembly. The tube will no longer be pressed against the tube housing wall. **E**

NOTE: Counterclockwise is viewed from facing the head of the pump.

- Remove and discard pump tube. **F**
- Remove roller assembly, and tube housing. On the adjustable pump also remove the shaft. Set them aside to reinstall later.
- Use a non-citrus all-purpose cleaner to clean chemical residue from the tube housing, roller assembly and cover.
- Check housing, cover and roller assembly for cracks and replace if cracked.
- Ensure rollers turn freely. Replace roller assembly if rollers are seized or worn or if there is a reduction or lack of output from the pump. **G**
- Reinstall the clean tube housing. On an adjustable pump, also install the shaft into the feed rate control.
- Apply Aquashield to the shaft tip.
- Install roller assembly.

Snap
counterclockwise
to collapse!



Tube Replacement

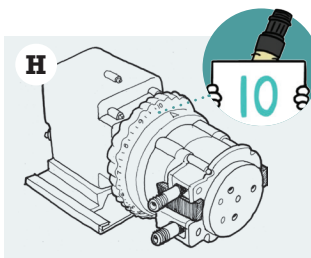

INSTALL TUBE

IMPORTANT! DO NOT LUBRICATE PUMP TUBE OR ROLLER ASSEMBLY.

1. Ensure power to pump is off and power cord is unplugged. On the adjustable model, ensure the feed rate is set to 10. **H**
2. Place new tube in the pump head; use your fingers to center it over the rollers. **I**
3. Place tube housing cover (feet first) on the tube housing, affix front latches to the cover lip and then press latches back to secure. Be sure the cover is seated with the sleeve bearing on the shaft and is flush with housing, before latching. **J**

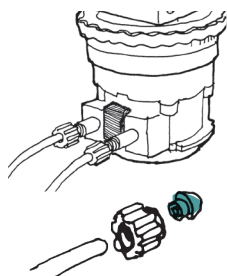
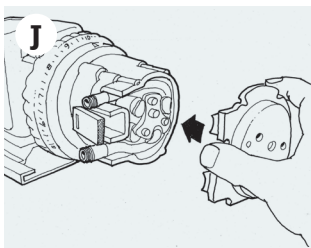
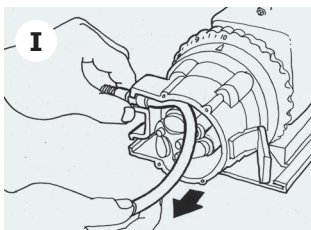

When using 1/4" connections, replace ferrules at every tube change, ferrules seal the connecting nut to the tube fitting.

Tube Replacement

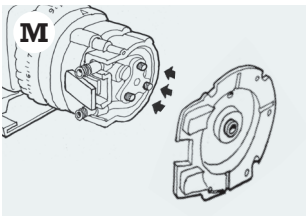
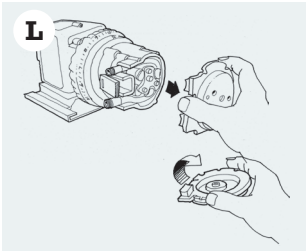
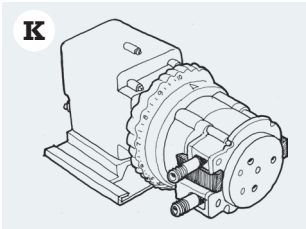

INSTALL TUBE continued

4. With cover latched, plug pump in and turn power on. Allow pump to run the roller assembly in collapsed position for approximately 4 minutes to relax tube. **K**

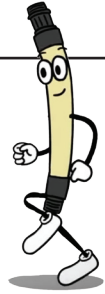

5. Turn pump off and unplug power cord.
6. Remove tube housing cover and flip to use as a tool in next step. **L**
7. Position cover feet near tube fittings. Place cover holes onto knurled lugs on roller assembly.
If using a Double Head Pump, slide innermost cover on shaft and position rivets next to knurled lugs on roller assembly. **M**

Tube Replacement

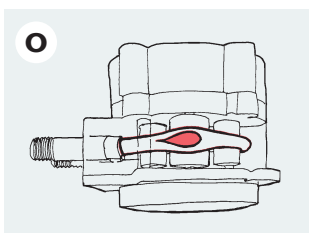
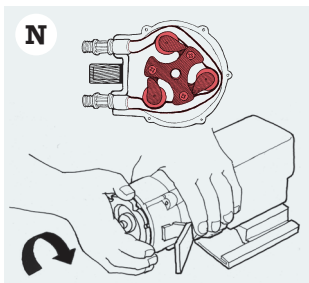

INSTALL TUBE continued

ADJUSTABLE MODEL ONLY

8. Expand roller assembly for the Adjustable Model

- Hold feed rate securely, use the cover and **gently** rotate the roller assembly clockwise to expand roller assembly. The tube will be pressed against the tube housing wall. **N & O**



NOTE: Clockwise is viewed from facing the head of the pump.

Go to page 27.

CAUTION: Use care when expanding roller assembly, excessive force can crack the hub and lead to roller assembly failure.



Expand roller assembly gently like soothing a baby

Before turning pump on, confirm roller assembly is expanded and tube is pressed against housing wall.

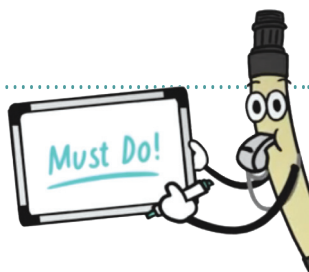

Tube Replacement

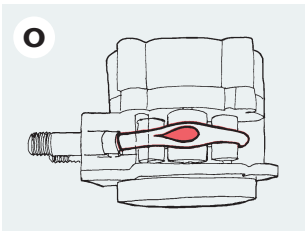
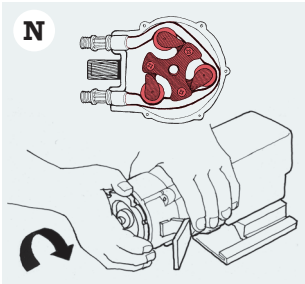

CAUTION: Use care when expanding roller assembly, excessive force can crack the hub and lead to roller assembly failure.



Expand roller assembly gently like soothing a baby



INSTALL TUBE continued

FIXED OUTPUT MODEL ONLY

8. Expand roller assembly for the Fixed Model.
 - a. Slide one latch out to remove from tube housing. Insert latch end into key slot in the vent in rear of motor housing. While pressing latch into rear of motor, **gently** rotate cover clockwise until it stops. Refer to the images below.

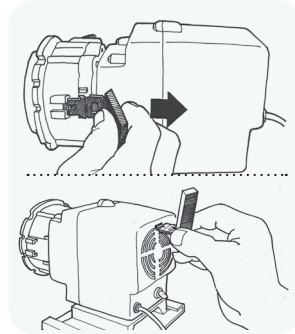

- b. Holding motor securely, use cover as a tool and quickly (snap) rotate the roller assembly clockwise to expand roller assembly. The tube will be pressed against the tube housing wall. **N & O.** NOTE: Clockwise is viewed from facing the head of the pump.
 - c. Remove latch from vent and reattach it to tube housing.

Tube Replacement

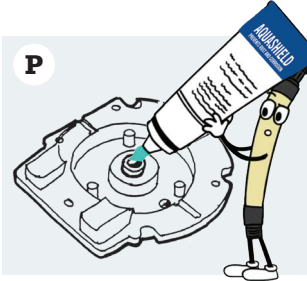

INSTALL TUBE continued

9. Apply a small amount of Aquashield to cover bushing **ONLY**. **DO NOT** lubricate the pump tube. **P**
10. Place tube housing cover (feet first) on the tube housing, affix front latches to the cover lip and then press latches back to secure. Be sure cover is seated with the sleeve bearing on the shaft and is flush with housing, before latching. **Q**

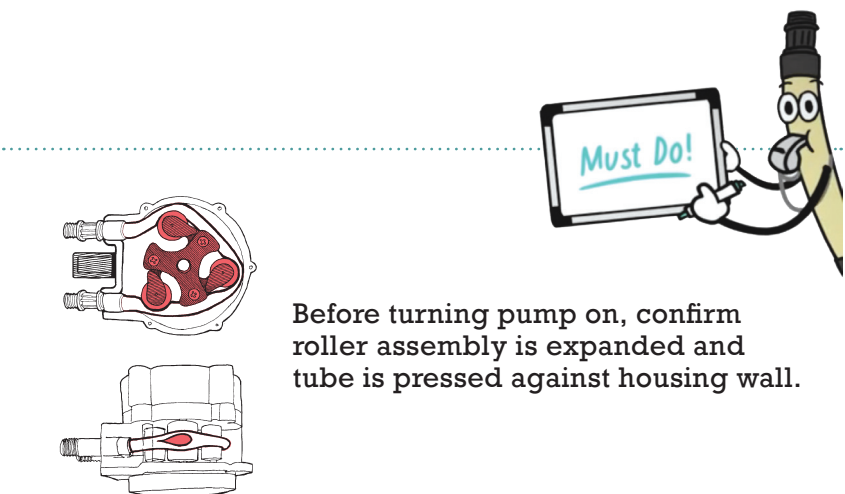
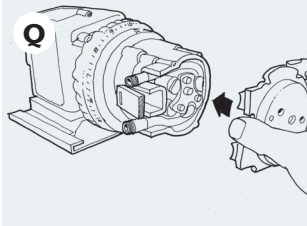

Before turning pump on, confirm roller assembly is expanded and tube is pressed against housing wall.

Tube Replacement

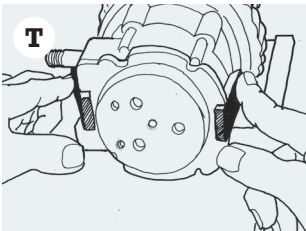
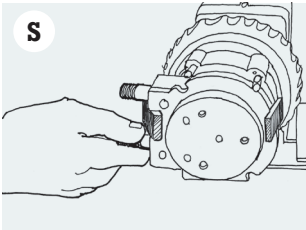
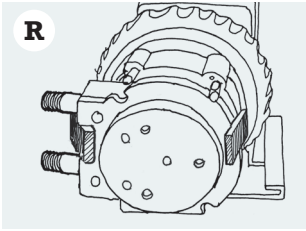

CENTER TUBE

1. Ensure pump is off. Lift latch located between tube fittings, leaving end of latch engaged with the lip on tube housing cover. Leave latch on opposite side closed. **R**
2. Plug pump in and turn on. Turn tube fitting on suction side not more than 1/8 of a turn in the direction tube must move. **S**
3. DO NOT let go of fitting until tube rides approximately in center of rollers.
4. Turn pump off, let go of fitting, and secure latch between the fittings. **T**

CE PUMP ONLY: Reinstall the safety screw on the cover.

5. Inspect suction & discharge lines, point of injection, and duckbill for blockages. Clean and/or replace as required. Always replace ferrules during tube change; failure to do so may lead to poor pump performance, including shortened tube life.
6. Reconnect suction & discharge lines. DO NOT allow tube fittings to turn inside the pump housing.
7. Turn pump on and run for 4 minutes to verify operation.

Pump Head Replacement

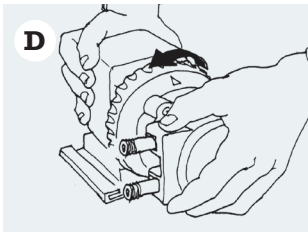
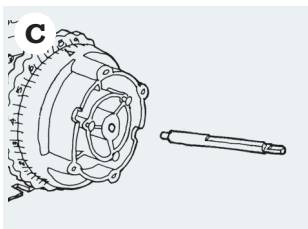
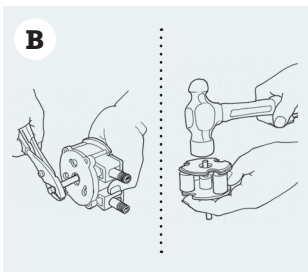
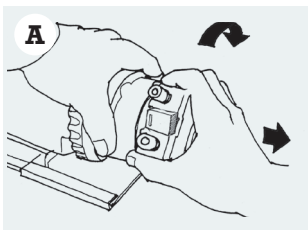

REMOVE PUMP HEAD & INSTALL NEW PUMP HEAD

ADJUSTABLE MODEL ONLY

1. Turn off Adjustable Model and unplug power cord.
 - a. To remove pump head, hold feed rate securely, grasp the head and turn clockwise until it stops. **A**
 - b. Remove head by pulling it straight out from the pump. The main shaft will come out with the pump head.
 - c. Using pliers, grasp main shaft and rock it back and forth (clockwise and counterclockwise) while pulling it straight out of the pump head. Set aside shaft to be reinstalled later. Discard old tube, housing and cover. If shaft will not come out, remove cover from pump head and use hammer to tap shaft from the front of the roller assembly to dislodge it. **B**
 - d. Insert the shaft back into feed rate. **C**
 - e. Put new pump head onto feed rate and turn counterclockwise until shaft falls into place.
2. Push pump head in while turning counterclockwise. Line up rivet holes on pump head with rivets on feed rate. **D**

3. Continue to push until rivets are inside the holes.
4. Turn pump head counterclockwise to secure rivets in rivet slots, firmly attaching the pump head.
5. Expand roller assembly & center tube. Refer to pages 25 and 27-28.

Pump Head Replacement

The illustration show the Classic Adjustable model.

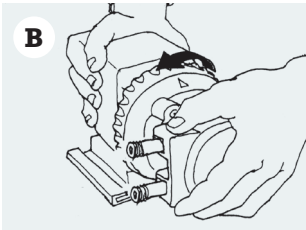
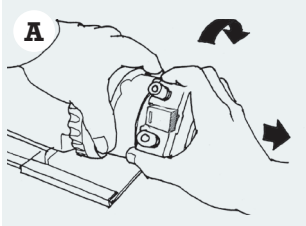

REMOVE PUMP HEAD & INSTALL NEW PUMP HEAD

FIXED OUTPUT MODEL ONLY

1. Turn off the Fixed Model and unplug power cord.
 - a. To remove head, hold motor securely, grasp head and turn clockwise until it stops. **A**
 - b. Remove tube housing & roller assembly together by pulling it straight out from the pump. The shaft will remain in the pump. Discard tube, housing and cover. If the housing & roller assembly are difficult to remove, insert a large, flat blade screwdriver between the pump body and head. Gently pry the head forward, ensuring the rivets on the pump body remain disengaged from the tube housing.
 - c. Put new pump head onto the motor and turn counterclockwise until shaft falls into place. **B**
2. Push pump head in while turning counterclockwise. Line up rivet holes on pump head with the rivets on the feed rate. **B**
3. Continue to push until rivets are inside the holes.
4. Turn pump head counterclockwise to secure rivets in rivet slots, firmly attaching the pump head.
5. Expand roller assembly & center tube. Refer to pages 26-28.

Feed Rate Control Basics

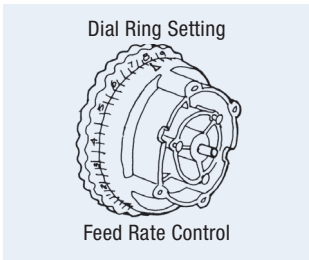

The Feed Rate Control (FRC) adjusts the pump output by utilizing a cam & spring loaded lifter assembly to control the rotation of the roller assembly according to the setting on the dial ring. The dial ring setting controls the amount of cam in the channel.

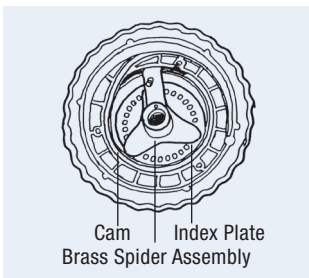

Inside the FRC is a spider assembly. Attached to the spider is the lifter and the index pin assembly. The index pin assembly consists of the pin & spring inside the holder.

When the pump is on, the spider assembly rotates. The lifter rides on the cam and the pin is retracted into the holder. When there is an opening in the channel, the lifter drops the pin into the channel.



The pin then engages the index plate which rotates the roller assembly and the pump injects according to the setting. The pump does not inject if the pin does not engage the index plate.

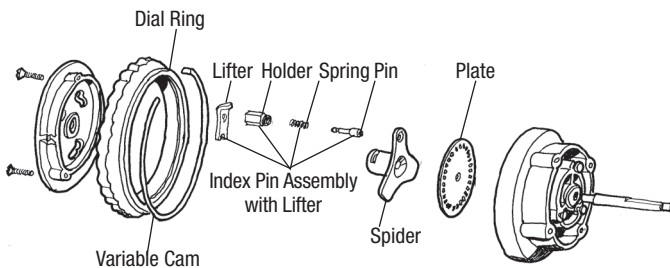

Feed Rate Control Wear



Worn parts affect dosing accuracy. Check the parts for wear if the feed rate control makes a skipping or ratcheting sound and/or the flow rate output is less than the setting.

CAM

At the lower settings, the lifter rides on a large section of the cam and will wear a groove in the cam. A groove in the cam will also contribute to wear on the lifter and index plate.

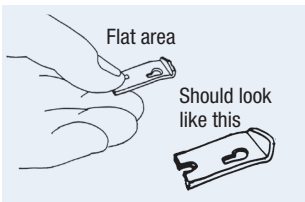

LIFTER

If the lifter wears and flattens, it may not fully lift the pin out of the index plate. The pin, which has a carbide tip, can drag across the index plate and make a ratcheting sound. The feed rate control will malfunction at different settings.

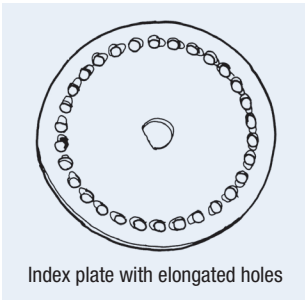

INDEX PLATE

A flattened lifter point or groove in the cam can cause the index pin to drag across the index plate and elongate the holes. Then, the pin will skip over the holes and the feed rate control will malfunction.

BEST PRACTICES

During Each Tube Replacement

- Inspect the cam, index plate & lifter and replace as required.
- The index plate can be inverted for use; remember to apply Aquashield. Refer to instructions on page 35.

Reduce Premature Wear On Parts

- Higher feed rate settings optimize the life of the feed rate control parts.
- For best results, select a pump with a maximum flow rate output closest to the maximum dosing requirement for your specific application.

Feed Rate Control Wear

SEIZED INDEX PIN AND/OR LIFTER ASSEMBLY

Water or chemical intrusion will corrode the pin and lifter causing them to seize; the feed rate will malfunction.

SOLUTION

1. Replace the index pin and/or lifter assembly as needed.
2. Review factory installation instructions.
3. Check the pump head:
 - If WATER INTRUSION is confirmed:
Wipe and dry roller assembly & tube housing and check the condition of the tube and replace if needed. If corrosion is apparent, replace the affected components.
 - If CHEMICAL INTRUSION is confirmed:
Use a non-citrus all-purpose cleaner to clean residue and dry the tube housing, roller assembly & cover. Check rollers turn freely. Replace any damaged components. If tube ruptured, replace it. If using a duckbill check valve, replace duckbill.

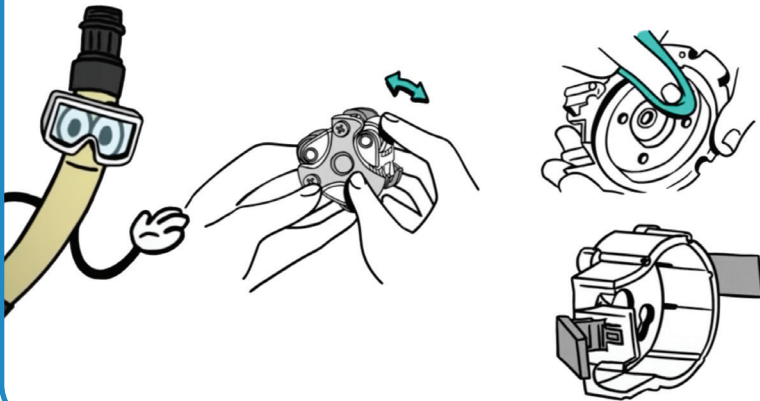

Feed Rate Control Parts Replacement

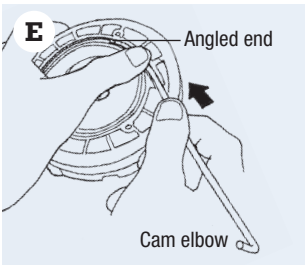
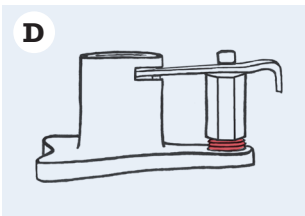
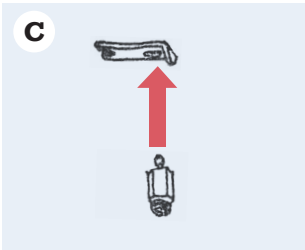
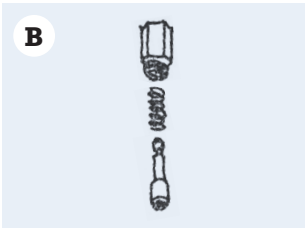
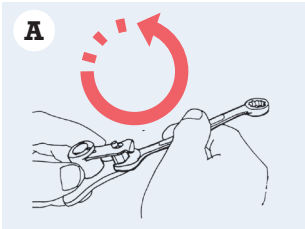

1. Remove and set aside:
3 screws, mounting plate, spider,
dial ring & index plate
2. If needed, replace lifter & re-assemble.
 - Unscrew holder with 3/8" wrench to
remove assembly from spider. **A**
 - Reassemble pin & spring into
holder. **B**
 - Push pin up & lock new lifter into
pin. **C**
 - Install assembly into spider. **D**
 - Place a drop of breakaway thread
locker* onto holder threads. **D**
 - Snug tighten holder to spider. Be
careful not to cross thread.
3. Invert worn index plate for use or install
new one.
4. Clean out channel before installing
new cam.
5. Apply Aquashield to lubricate angled end
of cam.
6. Feed angled end into channel and keep
cam elbow upright. **E**
7. Continue to feed cam until there is
approx. 1/2" space between angled
end and beginning of channel.

* A breakaway thread locker is a type of liquid adhesive to secure thread connections which can be separated by hand tools.

Feed Rate Control Parts Replacement

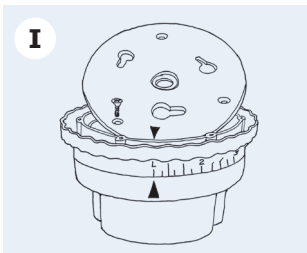
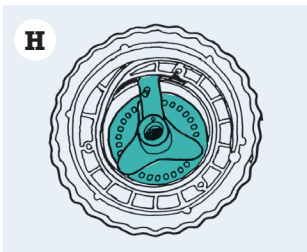
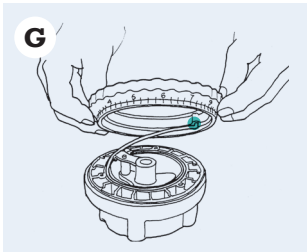
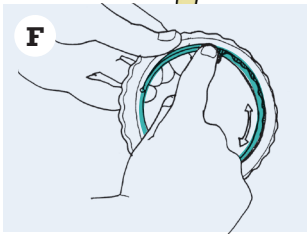

8. Apply Aquashield to inside of dial ring or it will be difficult to rotate. **F**
9. Insert cam elbow into dial ring boss. **G**
10. While keeping elbow in boss & cam in channel, pivot dial ring to gently place onto housing. **G**
11. Apply Aquashield to both sides of index plate and around edges of spider & lifter. **H**
12. Place spider assembly on index plate. The lifter should fit in the open space created in step 7. **H**
13. Install mounting plate; line up arrow on plate with arrow on housing. If arrows are not aligned, the dial ring will not rotate from L to 10. **I**

Install the self-tapping screws; back the screws into the original thread to prevent cross-threading.

Snug tighten; if overtightened the dial ring won't turn; if too loose, the motor will cause the dial ring to unintentionally turn to setting 10.

Motor Basics

The motor has a cylindrical rotor with shaft encased within a magnetic coil. When power is applied to the coil, the rotor rotates counterclockwise. The helical end of the rotor engages the series of gears in the gear case.

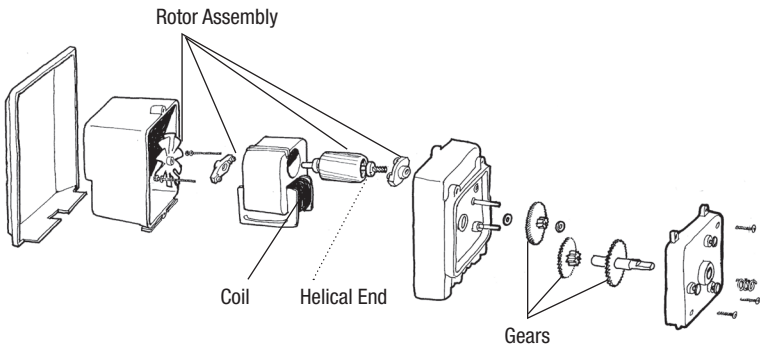
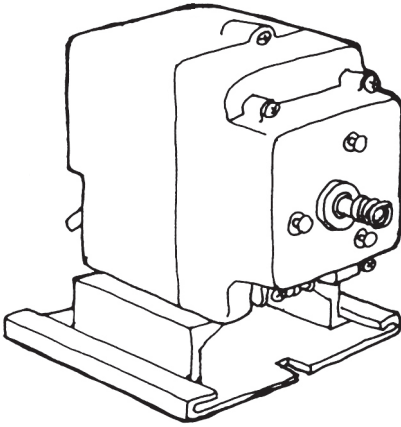

Motor Malfunction Causes

LIQUID INTRUSION

The motor is fan cooled and needs proper ventilation while protecting it from water intrusion.

SOLUTION

Mount the single head pump vertically with pump head downward and use the rain roof in outdoor installations, in areas subject to wash downs, or in wet environments.

CHEMICAL VAPORS

The motor won't rotate freely if the coil, rotor and bearing are rusted or corroded.

SOLUTION

1. Avoid mounting the pump over an open solution tank.
2. Review vertical installation for single head pumps.

INCORRECT VOLTAGE

The motor voltage must match power supply to avoid a burnt coil.

SOLUTION

Use a volt meter for confirmation.

DAMAGED BEARING BRACKETS

Cracked or broken bearing bracket(s) result in rotor misalignment and can cause the rotor to bind to the magnetic coil that may be evident by a humming sound.

SOLUTION

1. Check the condition of the brackets and phenolic gear.
2. Replace parts as needed.

Rotor Assembly Replacement

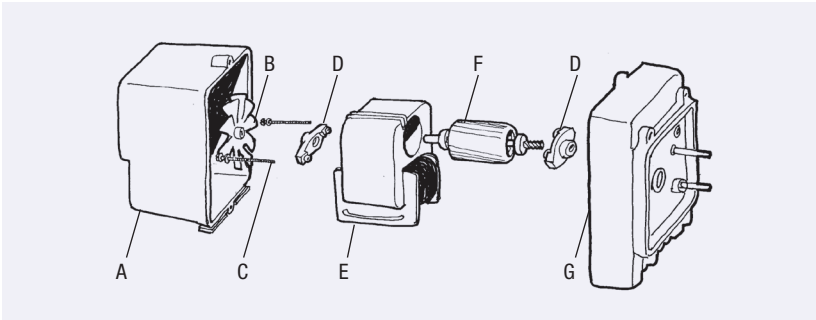

Rotor assembly includes **B, D & F**.

1. Remove and set aside:
 - 2 motor cover screws (not shown)
 - Motor cover **A**
 - Fan **B** (discard old fan)
 - 2 coil screws and lock washers **C**
 - Coil (keep wires connected) **E**
2. Remove and discard the rotor **F** and 2 bearing brackets **D**.
3. Press the new bearing bracket onto the threaded brass inserts in back of the gear case **G**. Make sure the tolerance ring is in place inside the bracket.
4. Install the new rotor by inserting shaft (helical gear side) onto the bearing bracket.
5. Place the coil **E** over the rotor **F** onto the bearing bracket **D**.
6. Snap into place the 2nd bearing bracket onto the rotor.
7. Insert 2 coil screws with lock washers and tighten. Thread screws manually to prevent cross threading.
8. Starting at an angle, press fan (with hub side down) onto rotor shaft.
9. Reinstall the 2 motor housing screws and tighten the self-tapping screws to secure the motor housing.

From this view, the copper rods are at the top right.

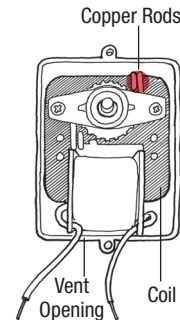

Coil Replacement

1. Disconnect power to pump.
2. Remove motor base & 2 motor screws.
3. Invert pump and use the pump head & feed rate control as a stand to work on the motor. Refer to illustration.
4. Remove fan and set aside.

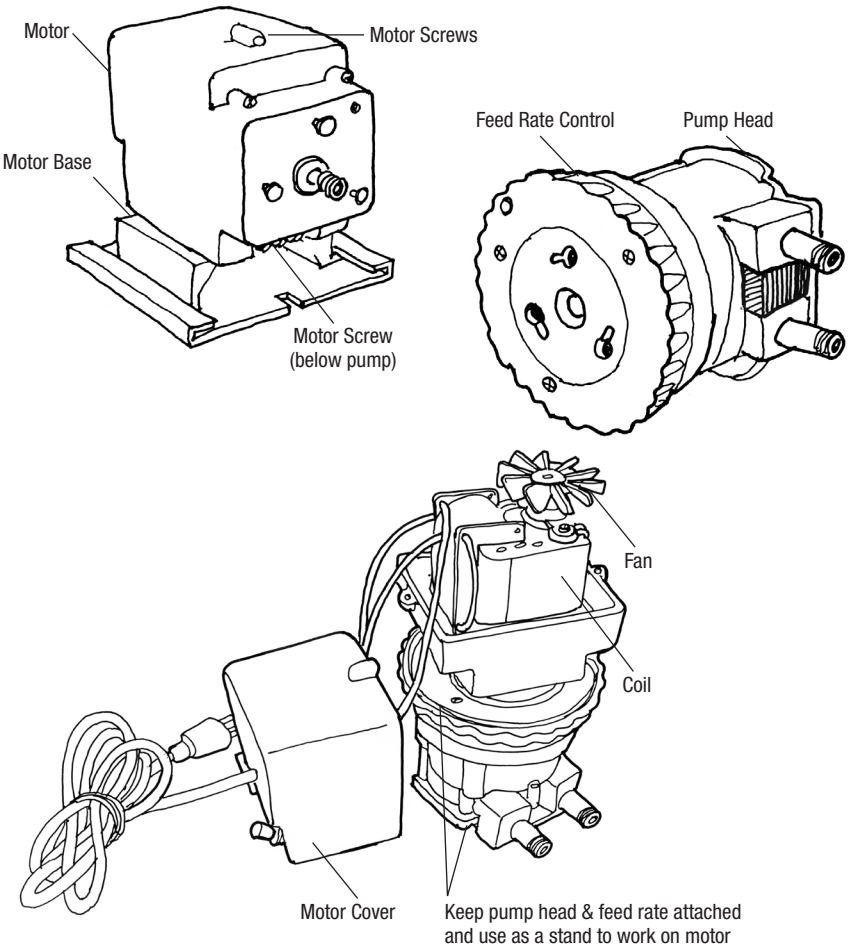

Coil Replacement

5. Disconnect ground wire with eyelet and set screw aside.
6. Cut coil wires from the motor cover at wire nuts. Cut power cord wires from the cover at wire nuts. Set aside cover.
7. Remove and set aside:
 - 2 coil screws and washers
 - Bearing bracket
8. Remove coil and discard.

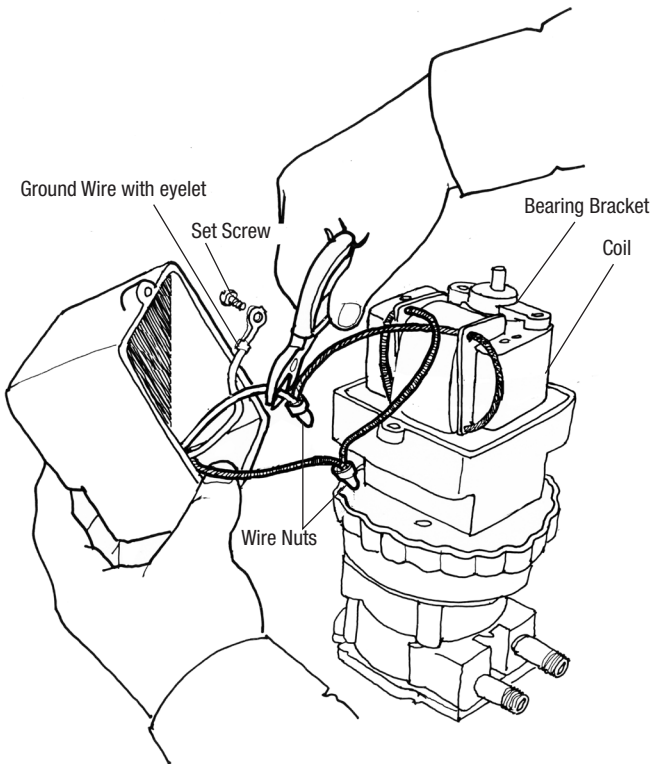

Coil Replacement

9. Install new coil.
Place bracket on rotor and securely seat onto coil.

Use the image below as a reference to confirm the coil is installed in the correct orientation.

On this view, the copper rods are located at the top right. If coil is in the wrong orientation the rotor will rotate clockwise.

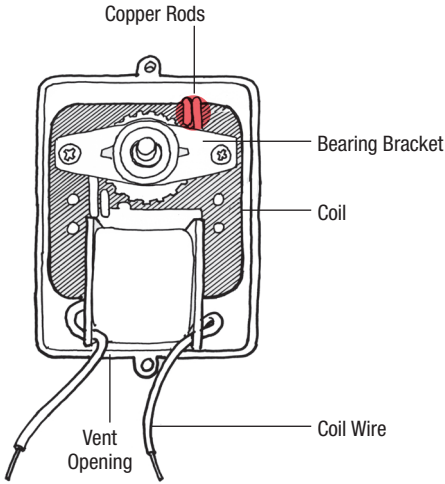

10. Install screws & washers and fasten bracket to the coil.
Thread screws manually to prevent cross threading.
11. Install fan.
With the metal band facing the bracket, press the fan flush on the rotor shaft.

Coil Replacement

12. With wire strippers set at 16 gauge, strip approx. 1/2" from the power cord & on/off switch wires.
13. Screw ground wire to the coil.
14. Crimp the stripped wires to each of the new coil wires.
15. Tuck wires into bottom of motor cover and secure in place. Back in the cover screws to catch original threads before tightening.
16. Apply power to the motor and test. If the coil runs backward, review step 9.

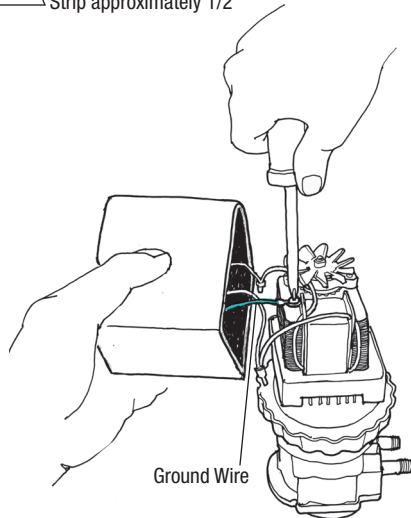
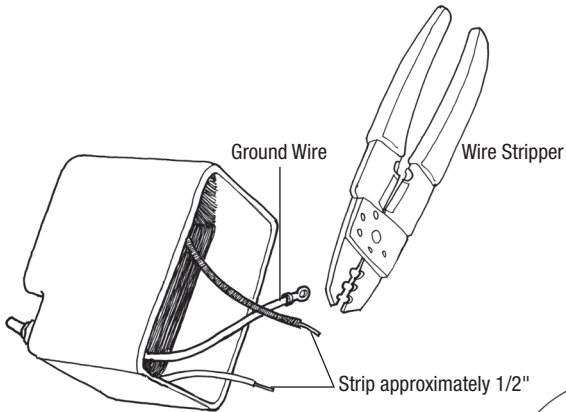

Gears

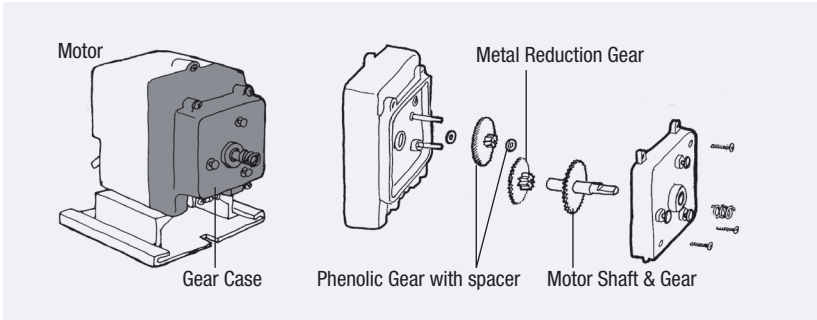

Located in the gear case, the metal reduction gear and phenolic gear control the revolutions per minute (rpm) of the feed rate and pump head.

The 45 & 100 models run at approx. 26 rpm and the 85 & 170 models run at approx. 44 rpm. The motor shaft & gear drives the feed rate control.

Gears

VISUAL DIFFERENCE IN GEAR SETS

45 & 100 Models

26 rpm

Both gear diameters 1 3/8"

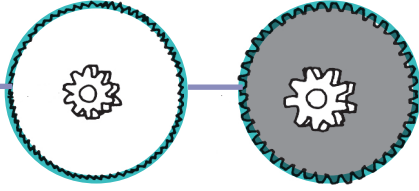

Phenolic Gear

Metal Reduction Gear

85 & 170 Models

44 rpm

Both gear pinions 9/16"

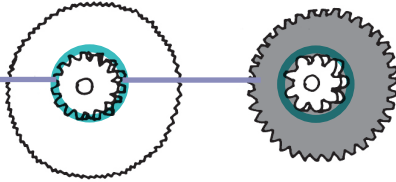

Gear Wear

Gear failure can be caused by misalignment mainly due to the wear over the service life of the pump.

Check for the following conditions possibly contributing to phenolic gear stripping:

- Water or chemical intrusion
- Cracked bearing bracket
- Worn gear posts
- Worn gear case cover
- Rusted helical gear
- Insufficient lubrication

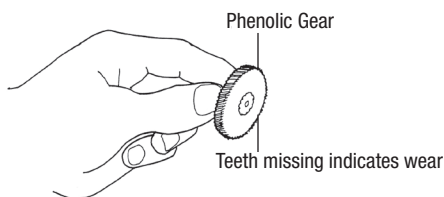

SOLUTION

1. Review factory installation instructions. Use a rain roof in outdoor applications or wet environments.
2. Replace gears with visible wear or corrosion.
3. Replace worn, rusted or corroded gear posts.
4. Inspect gear case & cover for cracks or corrosion and replace as needed.
5. Inspect the helical gear at end of the rotor. Buff off rotor if rusted or replace the rotor assembly.
6. Apply a generous amount of Aquashield to gear posts, pinions, gear rings and the motor shaft & gear.

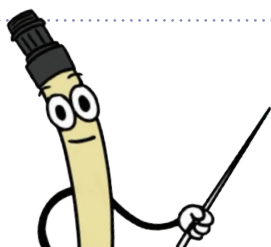

Refer to the Trouble Shooting guide in the *Classic Series Installation Manual* for pump conditions and solutions.

Gear Replacement

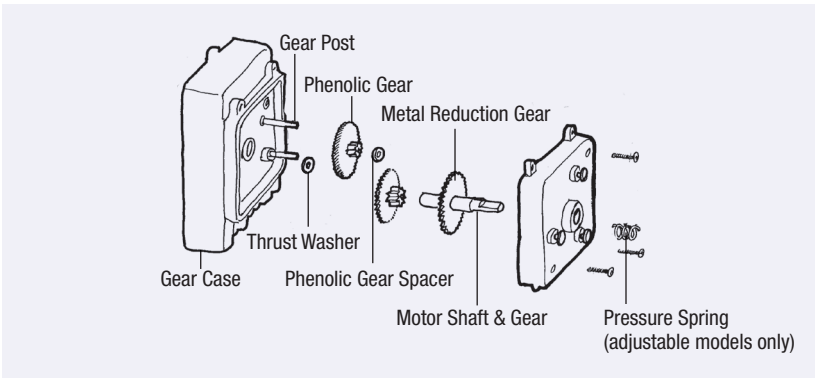

1. Remove 4 Phillips head screws from gear case cover.
2. Remove gear case cover.
3. Remove gears and inspect thrust washer and posts. To remove posts, grasp with pliers and pull straight out.
4. Wipe away grease, check for rust or corrosion on the rotor shaft. Remove with wire brush, any visible rust or corrosion prior to replacing gears.
5. Install gear posts by tapping with rubber mallet until bottomed.
6. Apply Aquashield on new gear posts before installing gears.
7. Install phenolic gear & spacer.
8. Install metal reduction gear.
9. Install thrust washer and motor shaft with gear.
10. Apply a generous amount of Aquashield on top of all 3 gears.
11. Reattach gear case cover with 4 screws and tighten. Screws must be backed in to locate original threads before securing, to prevent stripping screw boss.

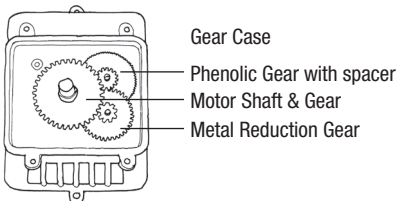

STENNER PUMPS

Series	Description	Max. Flow Rate Output & PSI	
Classic Series	Electromechanical, fixed output models or adjustable with 20:1 turndown	170.0 GPD 40.0 GPD	25 psi 100 psi
S Series	Interfaces with process control systems 9 operational modes, programmable relays	315.0 GPD 125.0 GPD	25 psi 100 psi
S420	Proportional injection by 4-20mA input	315.0 GPD 125.0 GPD	25 psi 100 psi
S Variable	Variable speed, 20:1 turndown	315.0 GPD 125.0 GPD	25 psi 100 psi
S10P	Proportional by dry contact water meter, flow switch or 12-24 VAC/VDC signal	30.0 GPD	100 psi
S128	Proportional dosing 1 oz solution to 1 gal water via dry contact water meter	10.0 oz/min	60 psi
Econ LD	Variable speed, accurate as low as 0.04 oz/hr, small footprint, light duty	50.7 oz/hr	80 psi
Econ FP	Proportional by dry contact water meter, flow switch or 12-24 VAC/VDC signal, small footprint, light duty	30.0 GPD	80 psi
Econ Integrator™	Built-in signal repeater. Proportional by dry contact water meter, flow switch or 12-24 VAC/VDC signal, small footprint, light duty	30.0 GPD	80 psi
Econ VX	Variable speed, small footprint, light duty	3.45 oz/min 2.09 oz/min	25 psi 80 psi
Econ FX	Fixed speed, small footprint, light duty	3.45 oz/min 2.09 oz/min	25 psi 80 psi
Econ Stennicator	Proportional dosing 1 oz solution to 1 gal water via dry contact water meter, small footprint, light duty	2.07 oz/min	80 psi
Econ Vaccinator™	Doses 1 gal liquid vaccine over 6 hours, small footprint, light duty	0.36 oz/min	80 psi
Econ Timer Series	7-day/24-event timer, small footprint, light duty		
Econ T	1.33 oz/min 25 psi, 1.92 oz/min 80 psi		
Econ TD	3.18 oz/min 5 psi; Specifically for d-Limonene		
Econ TD Battery	4.0 oz/min 5 psi; Portable		

STENNER PRODUCTS

Products	Description
Proportional Injection System	Classic 45 or 85 Fixed Rate & Water Meter (3/4", dry contact) & PCM & Flow Indicator ships pre-mounted to a panel for proportional injection based on water system flow.
Econ Integrator™ or Econ FP Meter System	Econ Integrator™ or Econ FP & Water Meter (3/4", dry contact) & Flow Indicator ships pre-mounted to a panel for proportional injection based on water system flow.
Econ Stennicator Meter System	Econ Stennicator & Water Meter (3/4", dry contact; 1 or 10 PPG or 1 PPL) & Flow Indicator ships pre-mounted to a panel to inject 1 oz of product into 1 gallon of water (1:128 fixed ratio).
Tank System	Classic 45 or 85, or any Econ, or S Series excl. models with S5 prefix shipped with a tank (7.5, 15 or 30 gallon; white or UV gray).
Tanks	White or UV gray, 7.5, 15 or 30 gallon
Water Meter	Activates pump by pulse, registers water usage. Dry contact reed switch, plastic or stainless, various sizes.
VPD Water Meter	Vertical positive displacement meter registers flow rates 0.1 to 22 GPM, reed switch, dry contact, 3/4", 1 PPG or 1 PPL.
PCM	Receives dry contact from water meter to activate Classic Fixed Output Pump for a preset time for proportional injection based on water system flow.
Flow Switch	Activates pump in constant flow water line for PVC or copper pipe, dry contact, 2-wire, paddle style, 3/4" or 1".
Flow Indicator	Visual guide confirms pump is injecting. Installed vertically on discharge line.

NOTES

NOTES

STENNER PUMPS®

STENNER PUMP COMPANY

3174 DeSalvo Road
Jacksonville, Florida 32246 USA

Phone: 904.641.1666

US Toll Free: 800.683.2378

Fax: 904.642.1012

sales@stenner.com

www.stenner.com

Hours (EST)

Mon.–Fri. 7:00 am–8:00 pm

 **Assembled in the USA**
with US and international components

© Stenner Pump Company

All Rights Reserved

Product illustrations by David Stiles
www.stilesdesigns.com

BSME 042524